

SILVERSTAR

U.S. Patent No. 7,057,812



The Award-Winning High-Definition Wall Screen



FEATURES

- High-Definition
- High gain (6.0)
- High contrast
- Light control is not critical
- Wide viewing area
- Outstanding color reproduction
- Extruded 1 1/2" black velvet finished frame
- Panels can be multiplexed for large presentations
- Screen is fully assembled and shipped in wood crate
- Custom sizes available
- Available in 16:10 format
- Optional tubular stand legs

SilverStar™ is Vutec's patented front projection screen with a gain of 6.0. This award-winning screen delivers the ultimate in picture quality, providing high brightness, vivid colors, high contrast and a 180 degree viewing area, putting it in a class by itself as a truly revolutionary high-definition screen.

SilverStar's superior performance begins with its innovative, patented technology—a silver-based material combined with multiple optical layers to provide the 6.0 gain. This state-of-the-art technology increases color saturation while expanding contrast in controlled or uncontrolled lighting environments.

SilverStar is custom made to order and can be multi-plexed for large theaters. With unsurpassed versatility, it is the screen of choice for home theater systems, retail displays, command and control, religious and educational venues.



TECHNICAL

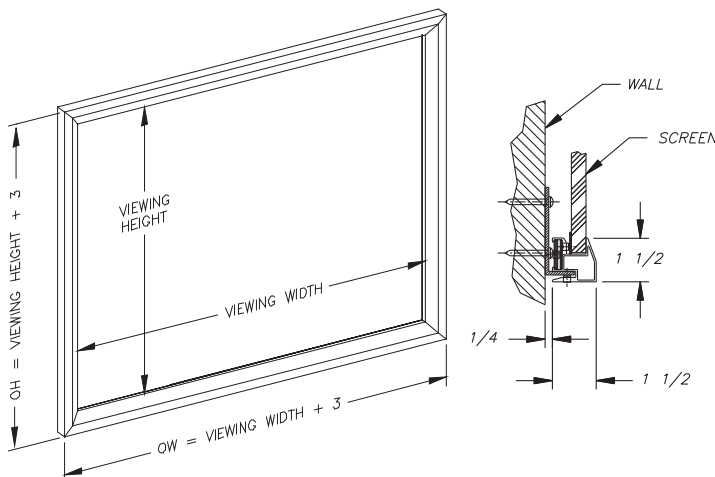

DIAGONAL SIZES

Pro AV (1:1) : 30" - 59"

Standard (4:3) : 72" - 100"

HDTV (16:9) : 92" - 123"

Widescreen (2.35:1) : 115" - 153"

INTENNIA

บริษัท อินเทนเนีย จำกัด
384 บางนาพรวิภา 94 เขตวัฒนากรุงเทพมหานคร
โทร. 02-934-6997 แฟกซ์. 02-934-6449
อีเมล : info@intennia.com
www.intennia.com

For more information please visit

